

Process Indicator

PRECISION

PIC153

OPERATING INSTRUCTIONS

Doc. name: OP INST PIC153 OP3102-V01

Selec Controls Pvt. Ltd., India

Tel.: +91-22-4141 8468 / 452

Website : www.selec.com

Email: sales@selec.com

A) OVERVIEW.

1.Features.....	1
2.Ordering information.....	2

B) SPECIFICATIONS.....3**C) INSTALLATION.**

1.Safety Information.....	7
2.Terminal connections.....	9
3.Sensor input wiring.....	10
4.Output wiring.....	10

D) PROGRAMMING.

1.Function menu.....	12
2.Key's description.....	13
3.Level 0-Input parameters.....	14
4.Level 1 Alarm Module(Alarm 1).....	17
5.Level 2-Alarm module(Alarm 2).....	17
6.Level 3-Analog o/p & special function module....	19
7.Level 4-Communication module.....	22
8.Level 5-lockout module.....	23

F) CALIBRATION CERTIFICATE 25

Overview



96 x 48



SALIENT FEATURES

❖ **Universal I/O:**

Inclusion of all possible inputs and outputs in a single product with high precision sensing & low temperature drift.

❖ **Customized Upper 5 Digit Alpha-Numeric Display:**

User can edit each digit as per requirements

❖ **Outputs:**

0 to 20mA, 4 to 20mA, 0 to 10V & 0 to 5V for retransmission & Manual output

❖ **Special Features:**

- 2 SPDT Relays for Alarm Actuation
- 24V, 100mA sensor supply for transmitter modules
- Single key Auto/Manual switching

Others

- ❖ Dual color 5 digit display
- ❖ Digital filtering
- ❖ Sensor break indication
- ❖ Sensor error compensation
- ❖ Programmable parameter lockouts
- ❖ 85 to 270 VAC/DC supply

Optional Features

- ❖ RS-485 MODBUS communication
- ❖ Compliance- **CE**
- ❖ IP65 front panel protection

2. ORDERING CODE

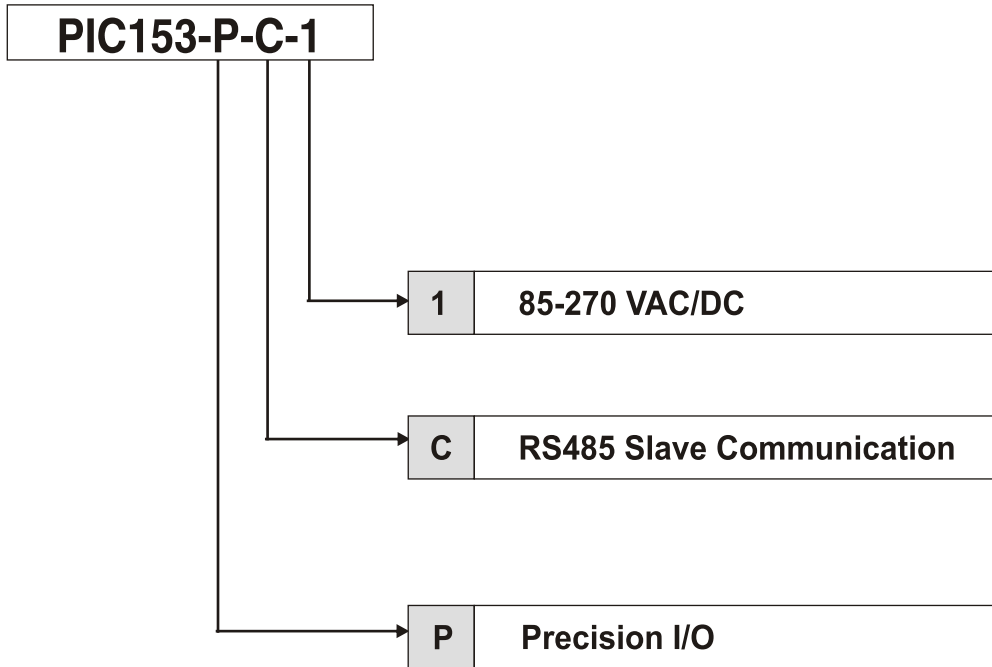

PIC153-P-C-1

- 1) Universal Input
- 2) 2 Number of SPDT Relays
- 3) Analog Output Current & Voltage
- 4) RS485 Slave Communication

1. TECHNICAL SPECIFICATIONS

1. DISPLAY

Display

PIC153- 48X96 - 5 digit 7-Seg LED Display with Selectable Dual color.

LED Status Annunciators

AL1,AL2,MAN(Manual),ACK,ERR

2. INPUT

Input	Thermocouple: J,K,T,R,S,C,E,B,N,L,U,W,Platinel II. RTD: PT100,PT1000 Signal inputs: -90 to 90mV,-10 to 10VDC,-20 to 20mA DC (Programmable scale type)
Sampling time	40ms.
Resolution	1/0.1 for TC/RTD. 1/0.1/0.01/0.001/0.0001 for Analog input (Decimal point position)
Indication accuracy	TC Input :0.1% of span at 25 °C R&S Input:0.25% of span at 25 °C RTD Input:0.1% at 25 °C Voltage:0.1% at 25 °C Current:0.1% at 25 °C
Digital filtering	OFF, 1 to 99 sec.

3.ALARM OUTPUT

Relay contact output	Relay 1, Relay 2 : NO: 10A@250VAC or 28VDC NO/NC: 5A/5A@250VAC Life expectancy : 50000 cycles at maximum load rating
-----------------------------	--

3.1 Retransmission output

Resolution	1mV approx for AOV and 1uA approx for AOI
Current output	Range: 0 / 4-20mA, Action: Retransmission Update rate:100ms,Maximum output load resistance:500E
Voltage output	Range:0-5 / 10V Action:Retransmission Update rate:100msec Minimum output load resistance:10k

4. FUNCTION

Alarms	Modes:Alarm high,Alarm Low,Band,Serr Hysteresis:Programmable Annunciator:Programmable Reset Action:programmable-Automatic or latched Standby/Hold:Programmable-Enable or disable Pdly:Power ON delay Rdly:Restart time delay
Auto/Manual Concept	User can switch from manual analog O/P to retransmission mode by pressing A/M key for 5sec. when in online mode. NOTE:User must feed the manual output % in HAND level 3

5. SERIAL COMMUNICATION

Interface standard	RS485
Communication address	1 ... 99, maximum of 32 units per line.
Transmission mode	Half duplex.
Transmission protocol	MODBUS RTU.
Transmission distance	500m maximum.
Transmission speed	115200,57600,38400,19200,9600,4800,2400 bits/sec.
Parity	None, Odd, Even.
Stop bits	1 or 2.
Response time	100ms (max and independent of baud rate).

6. ENVIRONMENTAL CONDITIONS

Operating range	0.....55°C
Storage range	-20 75°C.
Storage humidity	85% max. RH (non condensing) from 0 to 50°C.

7. POWER SUPPLY

Power supply	85.... 270VAC/DC.
Frequency	50/60Hz.
Power consumption	8VA max.

8. ISOLATION BREAKDOWN RATINGS

AC line w.r.t. all inputs and outputs	2500Volts
All other inputs and outputs w.r.t. Relay contacts	2500VAC

9. SAFETY AND EMC STANDARDS

Compliance	CE.
LVD	As per BS EN 61010.
EMC	As per BS EN 61326.
Panel sealing	IP65.

WEIGHT : PIC153-P-C-1 : 232gms

10. HOUSING:Flame retardant engineering plastic.

11.INPUT SENSOR RANGES(for 1°C resolution)

Sensor type	Range	Sensor type	Range
J	-200 to 750°C	E	-200 to 750°C
K	-200 to 1350°C	B	+149 to 1820°C
T	-200 to 400°C	N	-200 to 1300°C
R	0 to 1750°C	L	-200 to 600°C
S	0 to 1750°C	U	-200 to 900°C
C	0 to 2300°C	W	0 to 2300°C
Platinel II	0 to 1390°C	PT100	-200 to 850°C
PT1000	-200 to 850°C		

Signal inputs:

Input type	Range
Linear mV	-90 to 90mV
Voltage	-10 to 10VDC
Current	-20 to 20mA

12. INPUT DIP SWITCH SELECTION :

NOTE : The following parameters have been modified.

Short respective pins of JP1 as per the table given below for hardware selection of input sensor types :

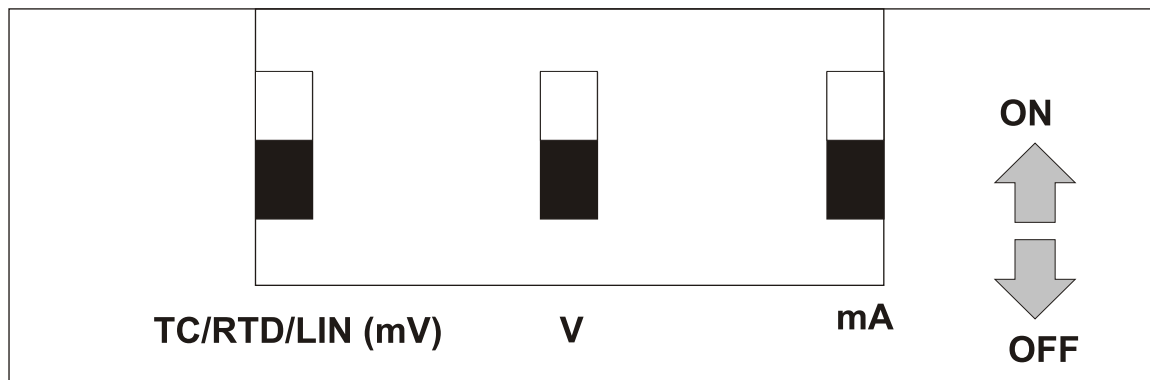

Push the respective switches upwards for hardware selection of Input sensor types.

Note : Sensor selection to be done in level 0 of programming also.

Installation

1. SAFETY INFORMATION

SAFETY SUMMARY

This manual is meant for the personnel involved in wiring installation, operation, and routine maintenance of the equipment. All safety related modifications; symbols and instructions that appear in this operating manual or on the equipment must be strictly followed to ensure the safety of the operating personnel as well as the instrument.

If the equipment is not handled in a manner specified by the manufacture it might impair the protection provided by the equipment.

 **CAUTION:** Read complete instructions prior to installation and operation of the unit.

 **CAUTION:** Risk of electric shock.

INSTALLATION INSTRUCTION

 **CAUTION:**

1. This equipment, being built-in-type, normally becomes a part of the main control panel and in such case the terminals do not remain accessible to the end user after installation and internal wiring.
2. Conductors must not come in contact with the internal circuitry of the equipment or else it may lead to a safety hazard that may in turn endanger life or cause electrical shock to the operator.
3. Circuit breaker or mains switch must be installed between power source and supply terminals to facilitate power 'ON' or 'OFF' function. However this switch or breaker must be installed in a convenient position normally accessible to an operator.

 **CAUTION:**

1. The equipment shall not be installed in environmental conditions other than those specified in this manual.
2. Fuse Protection - The equipment does not contain built-in fuse. Installation of external fuse for electrical circuitry is highly recommended. Recommended rating of such fuse shall be 275VAC/1Amp.
3. Since this is a built-in type equipment (finds place in main control panel), its output terminals get connected to host equipment. Such equipment shall also comply with basic EMI/EMC and safety requirements like BS EN 61326-1 and BS EN 61010 respectively.
4. Thermal dissipation of equipment is met through ventilation holes provided on chassis of equipment. Such ventilation holes shall not be obstructed else it can lead to a safety hazard.
5. The output terminals shall be strictly loaded to the manufacturer specified values/range.

MAINTENANCE

1. The equipment should be cleaned regularly to avoid blockage of ventilating parts.
2. Use soft cloth for cleaning. Do not use isopropyl alcohol or any other organic cleaning agent.

WIRING INSTRUCTION

⚠ CAUTION:

1. To prevent the risk of electric shock power supply to the equipment must be Kept OFF while doing the wiring arrangement.
2. Terminals and electrically charged parts must not be touched when the Power is ON.
3. Wiring shall be done strictly according to the terminal layout with shortest connections. Confirm that all connections are correct.
4. Use lugged terminals to meet M3.5 screws.
5. To eliminate electromagnetic interference use of short wire with adequate Ratings and twists of the same in equal size shall be made.
6. Cable used for connection to power source, must have a cross section of 1 or greater. These wires shall have insulation capacity made of at least 1.5KV.

ELECTRICAL PRECAUTIONS DURING USE

Electrical noise generated by switching of inductive loads can create momentary disruption, erratic display, latch up, data loss or permanent damage to the instrument.

To reduce noise:

A) Use of MOV across supply of temperature controller & snubber circuits across loads are recommended. part number are as follows:

1. Snubber: APRC-01

B) Use separate shielded wires for inputs.

C) The unit should preferably be shielded from the contactor

INSTALLATION GUIDELINES

Mechanical installation:

For installing the controller

1. Prepare the panel cutout with proper dimensions as shown.

OVERALL DIMENSIONS (All dimensions in mm)

Panel Cutout : 92mm X 46mm

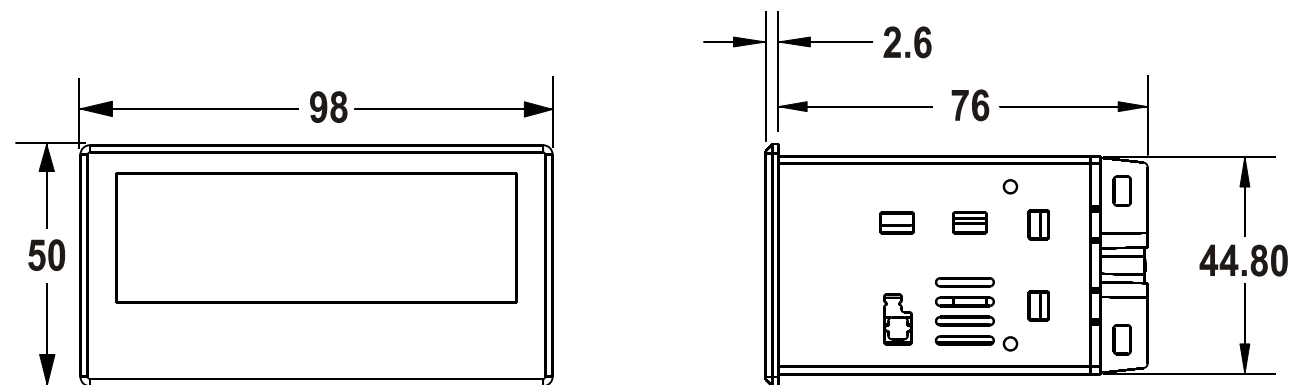

2. Remove the clamp from the controller.
3. Push the controller into the panel cutout. Secure the controller in its place by pushing the clamp from the rear side.
4. For proper sealing, tighten the screws evenly with required torque.

⚠ CAUTION:
The equipment in its installed state must not come in close proximity to any heating sources, caustic vapors, oils, steam, or other unwanted process by products.

EMC Guidelines:

1. Use proper input power cables with shortest connections and twisted type.
2. Layout of connecting cables shall be away from any internal EMI source.

2. TERMINAL CONNECTIONS

PIC153-P-C-1

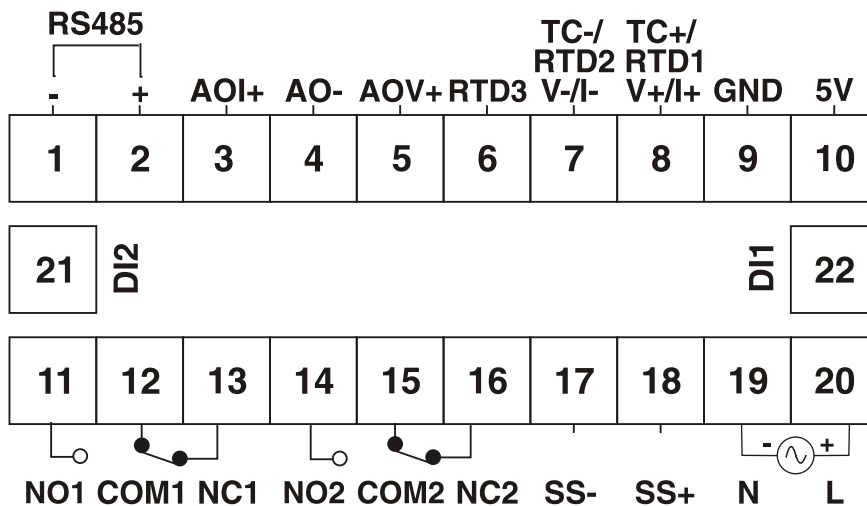

3. SENSOR INPUT WIRING

PIC153-P-C-1

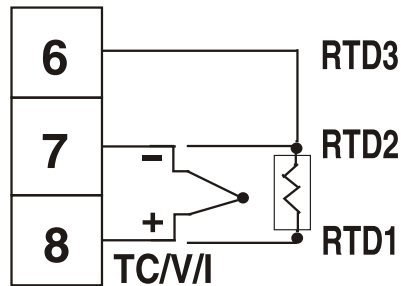

TC - Thermocouple (J, K, T, R, S, C, E, B, N, L, U, W, Platine II).

V - Voltage Input (-10 to 10 V DC).

mA - Current Input (-20 to 20mA DC)

RTD - PT100/PT1000

- NOTE :** 1) Refer input type selection in level 0 of programming menu.
 2) For 2 Wire RTD short terminals 6&7.

4.OUTPUT WIRING

Fig1. Analog Output – Linear voltage

PIC153-P-C-1

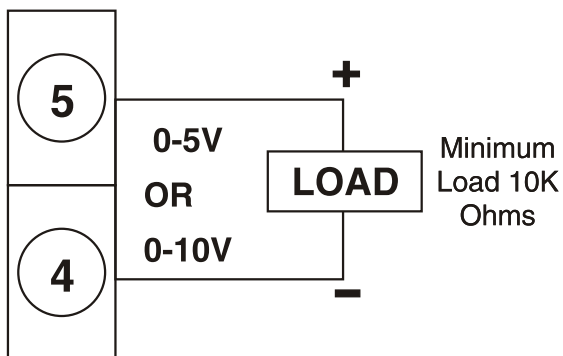

Analog Output -Linear current

PIC153-P-C-1

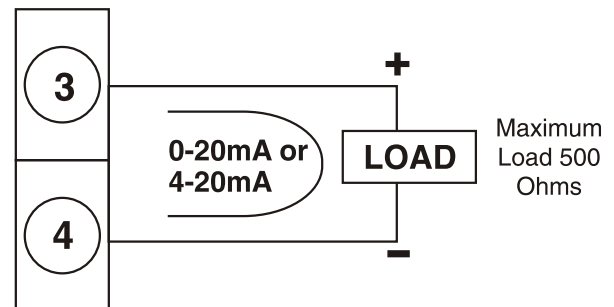
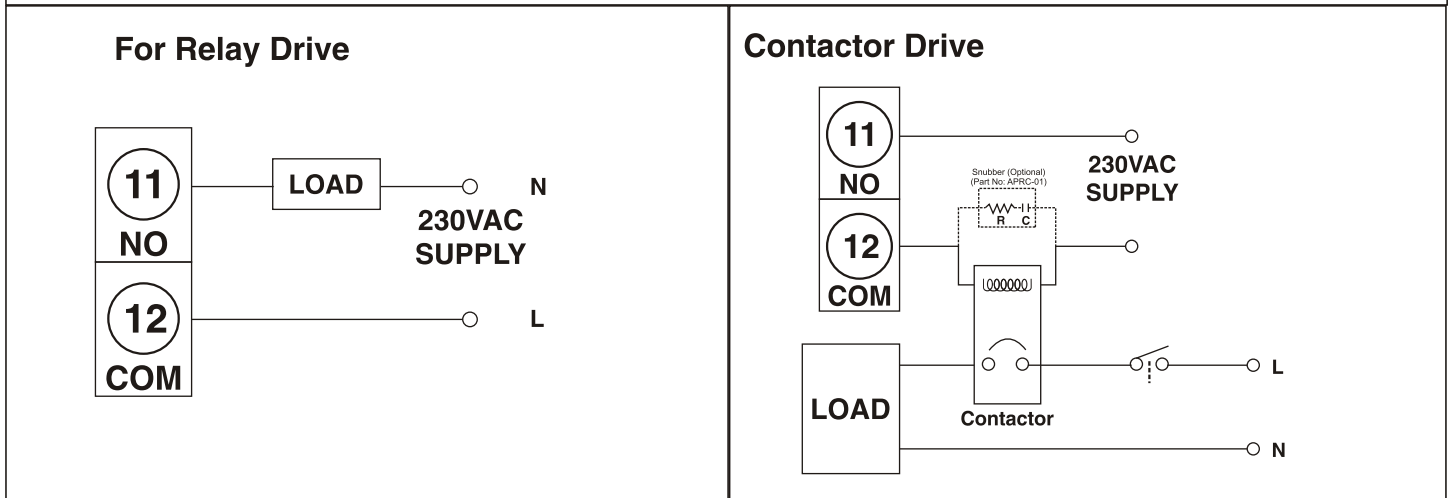

Fig2.Alarm Output– Relay to drive contactor (For single phase)

PIC153-P-C-1



NOTE: Use snubber as shown above to increase life of internal relay of temperature controller.

Fig.3 Loop Powered Transmitter input wiring

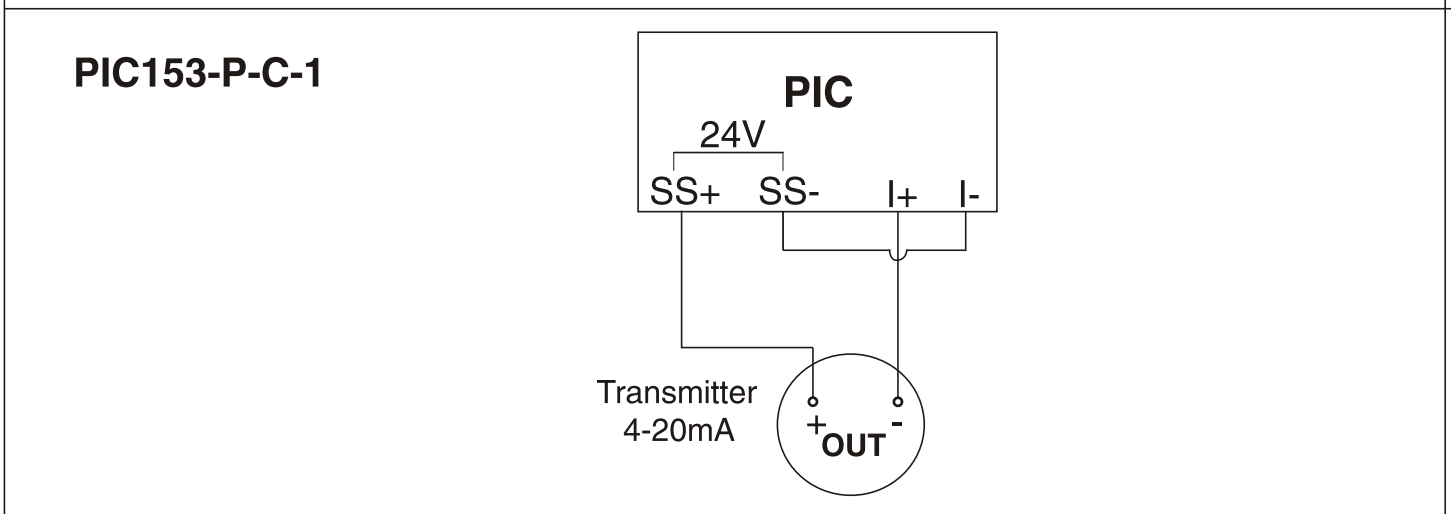
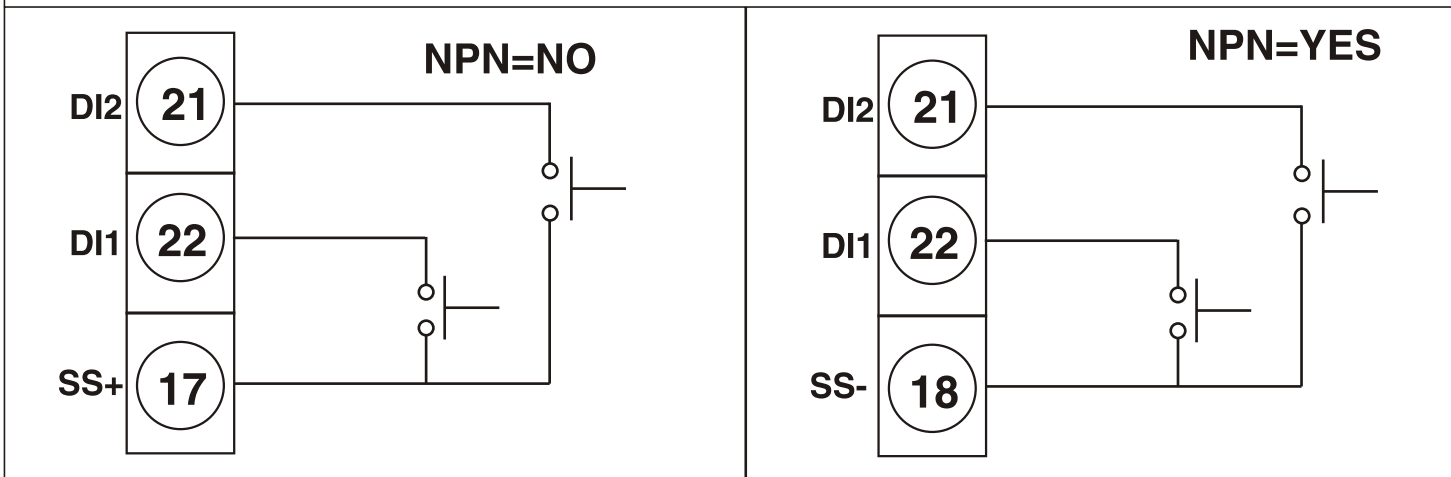

Fig4.DIGITAL INPUT WIRING DIAGRAM

PIC153-P-C-1



1. FUNCTIONS MENU

TO CHANGE LEVELS PRESS \checkmark + \leftarrow OR \rightarrow + \checkmark TOGETHER

LEVEL 1

Input type: INPT
 High Resolution: HPRES
 Resolution: RESL
 Temp unit: TEMP
 Display scaling low: DSC.L
 Input scaling low: ISC.L
 Display scaling high: DSC.H
 Input scaling high: ISC.H
 Reverse scaling: P.SCL
 Set point high limit: SPHL

PV Color Low: PU-L
 PV Color High: PU-H
 PV Color Normal: PU-N
 PV Color: PU-C
 Set point low limit: SPLL

INPUT PARAMETER

LEVEL 2

Alarm high limit: HA-1
 Alarm low limit: LA-1
 Alarm hysteresis: HYSL
 Hysteresis bias: HYS-b
 Power ON delay: PDLY
 Restart time delay: RDLY
 Alarm mode: AODE
 Latch: LETCH
 Hold: HOLD

Annunciator: ANN
 Alarm status: ALPA

ALARM MODULE(AL1)

LEVEL 2

Alarm high limit: HA-2
 Alarm low limit: LA-2
 Alarm hysteresis: HYSL
 Hysteresis bias: HYS-b
 Power ON delay: PDLY
 Restart time delay: RDLY
 Alarm mode: AODE
 Latch: LETCH
 Hold: HOLD

Annunciator: ANN
 Alarm status: ALPA

ALARM MODULE(AL2)

LEVEL 3

Digital input: DIN
 Analog input: ANP
 Analog output: AOUT
 Manual selection: ANAL
 Hand O/P percentage: HAND
 Analog low scale: A-LO
 Analog High scale: A-HI
 Sensor error level: SEERR
 PV bias: BIAS

Reset: PSET
 Rounding Increment: RNDG
 Standby mode: STND
 Filter time constant: FTC
 FTC selection: FSEL

ANALOG O/P MODULE

LEVEL 4

Baud rate: BRUD
 Communication station no.: ADDN
 Parity: PARI
 Stop: STOP

COMMUNICATION MODULE

LEVEL 5

ID: ID
 Lock level 0: L--0
 Lock level 1: L--1
 Lock level 2: L--2
 Lock level 3: L--3
 Lock level 4: L--4
 Reset Password: PESP
 New/Change Password: CHNG

LOCKOUT MODULE

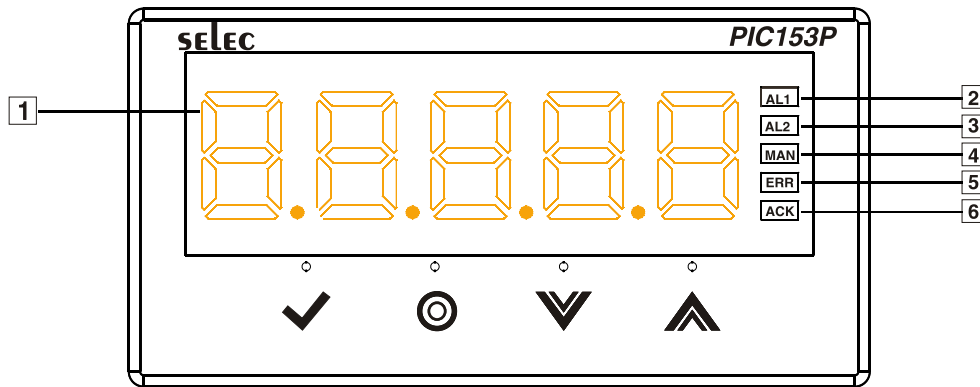

2.KEYS DESCRIPTION

Functions	Key press
To enter or exit program mode	▲ + ▼ together for 3 seconds
To change levels	▲+ ▼till Level is displayed. ✓+▲ / ▼to increase or decrease the level number.
To view function on the same level and to display the current option.	▲or▼ key once to view the next / previous function.
To increase or decrease the value of a particular function.	✓+▲ to increase and ✓ + ▼ to decrease the function value.
For switching from manual analog O/P to retransmission mode	Press A/M key ⊙ for 5sec
Alarm acknowledgement	Press ⊙ +▲ / ⊙ +▼ to select Alarm1 or 2 then press ✓+▲ or ✓+▼ to acknowledge

NOTE: The unit will autoexit program mode after 30 seconds of inactivity.

INDICATIONS AND DISPLAY

1 Process-value (PV)	Display the process temperature value.
2 AL1	Indication for Alarm1
3 AL2	Indication for Alarm2
4 MAN	Indication for Manual output & Standby mode
5 ERR	Indication for error
6 ACK	Latch Alarm Acknowledgement Request

PROGRAMMING OF LEVELS

3. LEVEL 0 - INPUT PARAMETERS

Display	Name & Description	Range	Display condition	Default value
INP E	<u>Input type</u> Select input type as Thermocouples: J,K,T,R,S,C,E, B,N,L,U,W. Platinel II. RTD: PT100,PT1000 Signal Inputs: Linear mV (-90 to 90mV), Voltage (-10 to 10V), Current (-20 to 20mA). Refer table on page 6 for input ranges.	J / E / E / R / S / C / E / B / N / L / U / V / P E N L P 100 / P E 1 E 100 / A U / 20 A R	—	J
HRES	<u>High resolution(5 digit display)</u>	NO / YES	This parameter is prompted only for analog input.	NO
RESL	<u>Resolution</u>	TC/RTD: 1 / 0.1 Analog input: 1 / 0.1 0.01 / 0.001 / 0.0001	Not prompted for R, S, and B type thermocouple.	1
TEMP	<u>Temperature unit</u>	°C / °F	TC/RTD inputs.	°C
DSC.L	<u>Display value scaling point1</u> #1 Feed the value of the display required at the lower value of analog input	+9999 To Display value scaling point2 (DSCH) -9999 To Display value scaling point2 (DSCH)	If HRES=YES & Analog Input If HRES=NO & Analog Input	0
ISCL	<u>Input value scaling point1</u> Feed the lower value of the analog input signal.	-20.0 mA / -9000 mV / -10.0V to Input value scaling point 2 (ISCH)	Analog Input.	As per input type selected.
DSC.H	<u>Display value scaling point2</u> #1 Feed the value of display required at the higher value of Analog input. analog input	Display value scaling point1 (DSC.L) to 99999 Display value scaling point1 (DSC.L) to 9999	If HRES=YES & Analog Input If HRES=NO & Analog Input	9999

Fixed 1°C resolution for R, S, B type thermocouple.

Display	Name & Description	Range	Display condition	Default value
ISCL	<u>Input value scaling point2</u> Feed the higher value of the analog input signal.	Input value scaling point1 (ISCL) to 2000mA / 9000mV / 1000V	Analog input.	As per input type selected.
RSCL	<u>Reverse scaling</u> Display scaling points can be reversed.	NO / YES		NO
SPHL	<u>Set point high limit</u>	Set point low limit (SPLL) to Max. Sensor range (99999) Set point high limit (SPHL) for Analog input.	If HRES=YES	750
		Set point low limit (SPLL) to Max. Sensor range (9999) Set point high limit (SPHL) for Analog input.	If HRES=NO	
SPLL	<u>Set point low limit</u>	Min. range of sensor Set point low limit (-19999) to Set point high limit (SPHL) for Analog input.	If HRES=YES	-200
		Min. range of sensor Set point low limit (-9999) to Set point high limit (SPHL) for Analog input.	If HRES=NO	
PU-C	<u>Process value Color</u>	Red/White/ AL-1/AL-2/ Ann	---	White
PU-N	<u>Process value Color-Normal</u>	Red/White	PV-C=Ann	White
PU-H	<u>Process value Color-High</u>	Red/White		Red
PU-L	<u>Process value Color-Low</u>	Red/White		Red

NOTE: 1. Whenever resolution is changed from 1 to 0.1 SPLL and SPHL is limited to -1999 and 9999 respectively.

2. #1-Display is with fixed 1° resolution for TC/RTD and as per decimal Point selected for analog input.

PARAMETER EXPLANATION:

• TEMPERATURE UNIT:

The temperature unit is selectable between °C and °F. When temperature unit is changed, the temperature ranges will also be changed according to the present selection of unit. If changed, be sure to check all parameters.

• RESOLUTION:

The resolution is selectable between 1 and 0.1 for TC and RTD inputs whereas it is selectable between 1, 0.1, 0.01, 0.001, 0.0001 for analog inputs. If changed, be sure to check all parameters.

• SCALING FOR ANALOG INPUT:

To scale the controller, two scaling points are necessary. Each scaling point has a coordinate pair of display values and input values. It is recommended that the two scaling points be at the low and high ends of the input signal being measured. Process value scaling will be linear between and continue past the entered points to the limits of the input range. (Factory setting example will display 0.0 at 0mA input and display 99999 at 20.00 mA input.)

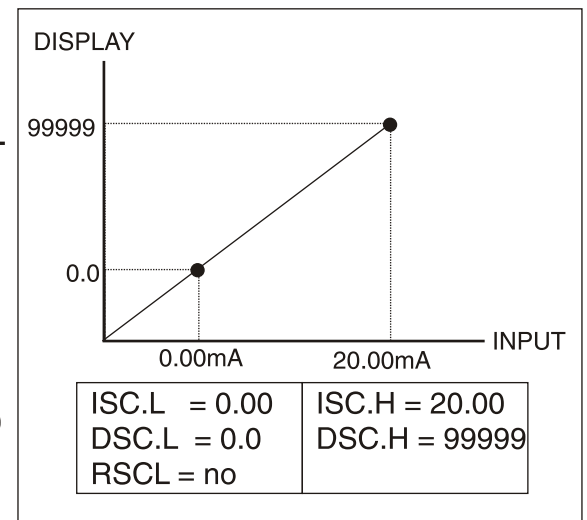

Reverse acting indication can be accomplished by setting **reverse** scaling parameter as YES. In this case **referring the above eg.** For 0.00mA input the display will show 99999 and 20.00mA input the display will show 0.0

NOTE: This change will not be visible in the programming menu.

• SET POINT LIMIT VALUES:

The controller has programmable high and low set point limit values to restrict the setting range of the set point. Set the limit values so that the temperature set point value cannot be set outside the safe operating area of the process.

• Process value color:

If in PV-C, ANN is selected then conditionally 3 parameters will be enabled.

PV-N, PV-H, PV-L, (PV-Normal, High & Low Respectively)

• Function of RED/WHITE in PV-C parameter:

In online mode, PV will be shown in RED or WHITE depending on the selection. No conditional change of color will be occurred.

• Function of AL-1 & AL-2 in PV-C parameter:

In online mode, PV will be shown in white for no alarm condition and will turn RED once an alarm occurs depending on the selection.

• Function of ANN in PV-C parameter:

In Online mode, PV will be shown by the color selected in PV-N, PV-H & PV-L (PV-Normal, High & Low Respectively).

4.LEVEL1&LEVEL 2 - ALARM MODULE

Display	Name & Description	Range	Display condition	Default value
HA	High Alarm	LA to SPHL (Band Mode) SPLL to SPHL (HA Mode)	This parameter is not prompted If alarm mode is off	750
LA	Low Alarm	SPLL to HA (Band Mode) SPLL to SPHL (LA Mode)		-199
HYS	Hysteresis	0.1 to 99.9 (For TC/RTD); 0.1 to 99.9 (For Analog Input) as Per decimal point		1.0
HYS.b	Hysteresis bias	TC/RTD: -9.9 to 9.9 Analog I/P: -9.9 to 9.9 as per decimal point	This parameter is not prompted If alarm mode is off	0.0
PdLY	Power ON delay	0.00 to 99.59min		0.00
RdLY	Restart time delay	0.00 to 99.59min		0.00
AL-1	Alarm Mode	OFF/HA/LA band/5.bP		HA
LECH	Alarm latch	OFF/ON		OFF
HOLD	Hold Alarm	OFF/ON		OFF
ALP	Relay status for Alarm1	EN/dEN		EN
ANN	Alarm Annunciator	OFF/ON		OFF

PARAMETER EXPLANATIONS:

- **ALARM MODE:**

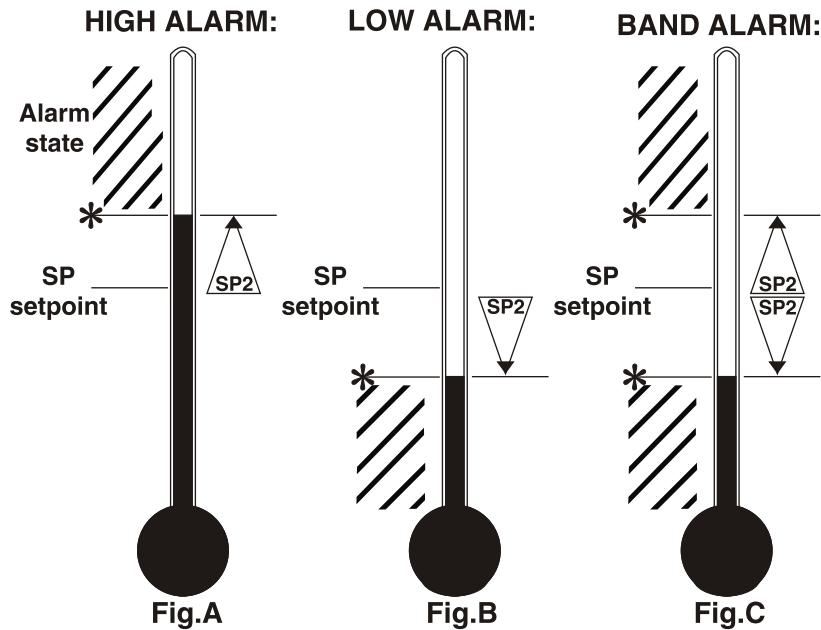

- **HIGH ALARM:**

The alarm is turned ON when PV rises above Preset value.

- **LOW ALARM:**

The alarm is turned ON when PV falls below Preset value.

- **BAND ALARM:**

The alarm is turned ON when PV rises above or Falls below a preset value.

- **SENSOR BREAK ALARM:**

The alarm is turned On in case of:

A) measurement value exceeds range

B) sensor reverse condition (applicable for TC/RTD)

- **POWER ON DELAY:**

Power ON delay is a delay that allows the main controller in a panel to synchronise the system without the indicator sounding an alarm.

- **RESTART TIME DELAY:**

The Restart Time delay is the time it takes to reactivate internal relays once they have been deactivated.

- **ALARM LATCH:**

When Latch is ON, the alarm once activated remains activated even when the error is removed. to deactivate the alarm, it has to be acknowledged by selecting AL-NO from the front online options and pressing ✓+▲

- **HOLD ALARM:**

When HOLD is ON, in any alarm mode, it prevents an alarm signal On power-up. the alarm is enabled only if the process temperature is within the alarm range.

- **ALARM ANNUNCIATOR:**

The annunciator can be disabled by selecting function ANN as OFF. Display blinks at the rate of 0.2sec. Display flashing b/w PV and message at 1sec.

5. LEVEL 3 - ANALOG O/P AND SPECIAL FUNCTION MODULE

Display	Name & Description	Range	Display condition	Default value
dIN	<u>Digital Input</u>	Keys/None	_____	None
nPN	<u>Analog Input</u>	YES / NO	This parameter is prompted only if , DIN=Keys	NO
A-OUT	<u>Analog output</u>	4-20; 0-20; 0-5V; 0-10;	_____	4-20
MANL	<u>Manual selection</u>	YES / NO	_____	NO
HAND	<u>Hand percentage</u>	0.00 to100.0%	MANL=ON	0
A-LO	<u>Analog low scaling</u>	+9999 to99999	If HRES=YES & This parameter is prompted Only if manual is OFF	0
		-9999 to9999	If HRES=NO & This parameter is prompted Only if manual is OFF	
A-HI	<u>Analog High scaling</u>	+9999 to99999	If HRES=YES & This parameter is prompted Only if manual is OFF	1000
		-9999 to9999	If HRES=NO & This parameter is prompted Only if manual is OFF	
SERR	<u>Sensor error level</u> Inc case of sensor failure The output can be set to high or low value of range.	HIGH / LOW	_____	HIGH
bIAS	<u>PV bias (Display Offset)</u>	-99.9 To +99.9 For TC(RTD) & -99.9 To +99.9 for AIN models decimal point as Per selected.	_____	0.0

Display	Name & Description	Range	Display condition	Default value
FSEL	FTC selection	YES/NO	—	YES
FTC	Filter time constant	1 to 99 sec.	Only if, FSEL=YES	1
ROUND	Rounding	0.1 to 10.0 for TC/RTD display As per decimal Point selected For analog input	TC / RTD with resolution = 1°C or Analog input.	1.0
STND	Standby mode	NO/YES	—	NO
RESET	Reset	NO/YES	—	NO

PARAMETER EXPLANATIONS:

• HAND OUTPUT PERCENTAGE:

This parameter can be used when a fixed percentage of output is desired. For eg.if 4-20mA analog output is being used and the desired output is 12mA,the hand percentage can be programmed as 50%.this will ensure that the analog output available is fixed 12mA i.e.50%.

NOTE:if Hand Output % is set as OFF Unit is in Retransmission Mode.

• ANALOG RETRANSMISSION:

In case of analog retransmission only the following parameters will be promoted:

- 1)A-LO:Analog low scalling.
- 2)A-HI:Analog high scalling.
- 3)S.ERR:Sensor error level.

Display is with fixed 1° resolution for TC/RTD and as per decimal point selected for analog input.

• SENSOR ERROR LEVEL:

This parameter determines the analog retransmission output level in case sensor failure.For eg:In case of 4-20mA retransmission output,if the sensor error level is set to High,20mA will be Available at the output at all times incase of input sensor failure.

• PV BIAS:(DISPLAY OFFSET)

This function is used to adjust the PV value in cases where it is necessary for PV value to agree with another recorder or indicator or when the sensor cannot be Mounted in correct location.

Parameter explanation:

• FILTER TIME CONSTANT:

The filter is an adaptive digital filter that discriminates between measurement noise and actual process changes. If the input signal is increasing too greatly due to measurement noise, increase the filter value. If accurate control is desired, increase the filter time constant whereas if the fastest controller response is required, decrease the filter time constant.

• ROUNDING INCREMENT:

This feature can be used to round off the display to a higher value than “1” in cases where the process input and in turn the display is fluctuating. Rounding selections other than 1 cause the process value to round to the nearest rounding selected. For Example: A rounding increment value of 5 causes 122 to round to 120 & 123 to round to 125. This parameter is not applicable when the resolution is 0.1 (for TC/RTD) Set point values, set point limits, Alarm values, input scaling values, and Analog scaling values are not affected by rounding. The rounding increment is for controller Display only and does not affect (improve or degrade) the control accuracy of the unit.

• STANDBY MODE:

This feature is useful during machine wiring. If standby mode is selected as YES, the following conditions exist:

- a. All displays are OFF.
- b. All outputs are OFF i.e. AL1, AL2, ACK, ERR & LED's are OFF.
- c. MAN Indication is ON
- d. Analog output is limited to the lower range.
- e. All front keys are disabled.
- f. Access to configuration enabled.

The STND status is preserved on power OFF.

LEVEL 4 - COMMUNICATION MODULE

Display	Name & Description	Range	Display condition	Default value
6AUd	Baud Rate	2400/ 4800/9600/ 19200/38400/ 57600/115200	—	9600
Add	Communication station No.	1 to 99	—	1
PAR 1	Parity	none/EVEN odd	—	none
STOP	Stop bit	1/2	—	1

CONNECTION DIAGRAM:

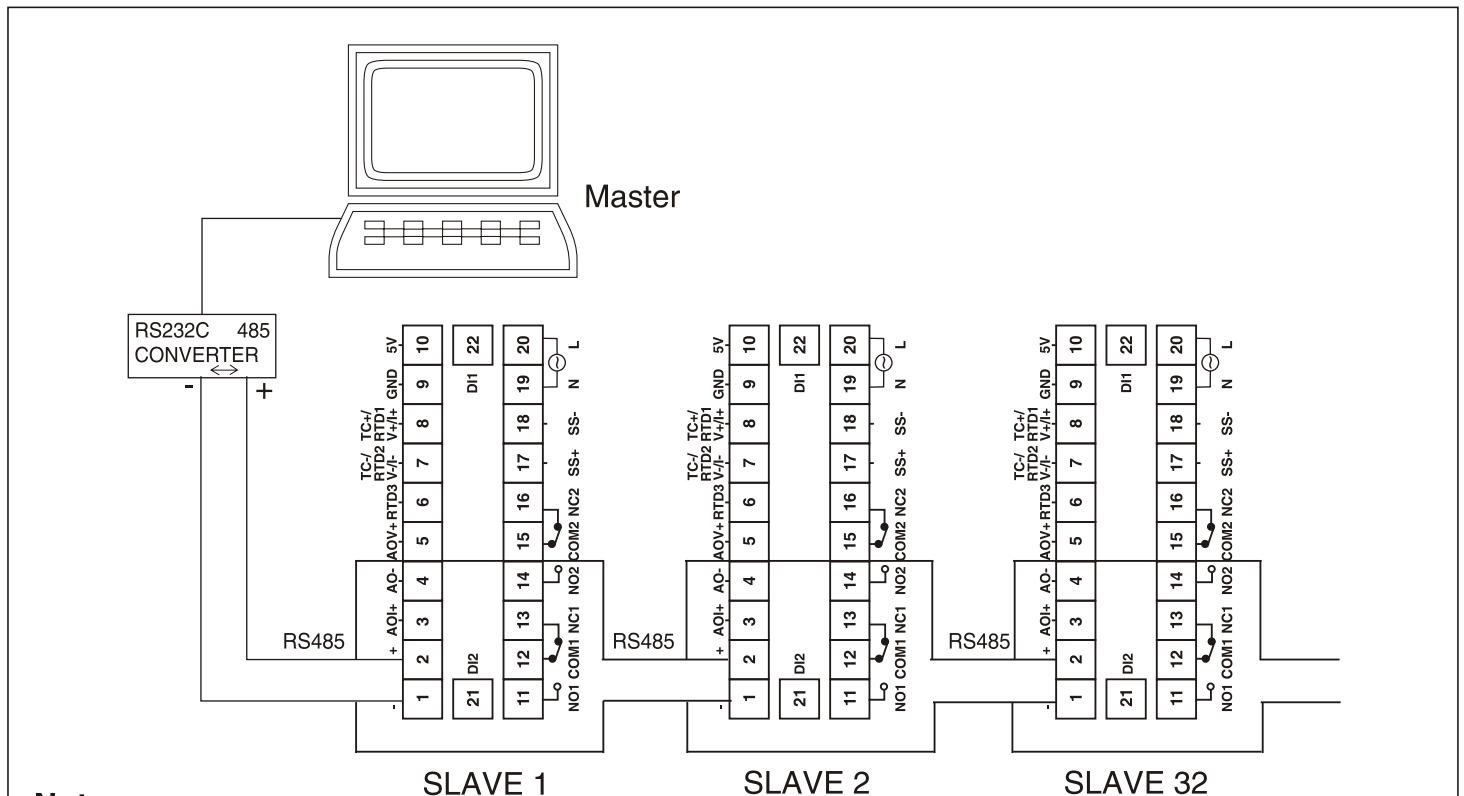

Note:

1. Maximum 32 slave controllers can be connected to the master.
2. The total cable length should not exceed 500 meters.
3. Use shielded twisted -pair cables for RS485 connections.
4. Use terminators having a resistance of 100ohm (1/2 watt).

RS485-RS232 Converter
Part no.- AC-RS485-RS232-01

LEVEL 5 - LOCK LEVEL:

Display	Name & Description	Range	Display condition	Default value
Id	<u>User ID</u>	0 To 99999	—	00000
L -- 0	<u>Lock Level 0</u>	UNLK/READ /LOCK	—	UNLK
L -- 1	<u>Lock Level 1</u>	UNLK/READ /LOCK	—	UNLK
L -- 2	<u>Lock Level 2</u>	UNLK/READ /LOCK	—	UNLK
L -- 3	<u>Lock Level 3</u>	UNLK/READ /LOCK	—	UNLK
L -- 4	<u>Lock Level 4</u>	UNLK/READ /LOCK	—	UNLK
RESP	<u>Reset Password</u>	NO/YES	—	NO
CHNG	<u>New/Change Password</u>	0 To 99999	RESP=YES	0

NOTE:

UNLK - Full access to the particular level / parameter.

READ - Particular level / parameter can be read but not edited.

LOCK - No access to the particular level / parameter.

Sensor Error Table :

Sensor Type	Error Cindition	Display
TC/RTD	PV > Sensor's Span Value	SBRK
	PV < Sensor's Low Value	SREV
Analog Input mV/I/V	PV > 9999 (For HRES=0)	SBRK
	PV > 99999 (For HRES=1)	
	PV < -9999 (For HRES=0)	SREV
	PV < -19999 (For HRES=1)	

Model No: PIC153-P-C-1

Claimed Accuracy: $\pm 0.1\%$ of full scale ± 1 digit (After 20min warmup time)

Standard used for calibration of the product is traceable to NABL

The calibration of this unit has been verified at the following values:

SENSOR	CALIBRATION TEMP (°C) (0.1 resolution)	DISPLAY VALUE (°C)	SENSOR	CALIBRATION VALUE (0.1 resolution)	DISPLAY VALUE
K	35.0	35.0	Voltage (VDC)	0.0	0.0
	700.0	700.0		10.0	10.0
	1350	1350			
PT100/ PT1000	0.0	0.0	Current (mA)	0.0	0.0
	500.0	500.0		20.0	20.0
	800.0	800.0			

The thermocouple / RTD curves are linearised in this microprocessor based product, and hence the values interpolated between the readings shown above are also equally accurate, at every point in the curve.

Unit is accepted as accuracy is within the specified limit of claimed accuracy and certificate is valid upto one year from the date of issue.